



baumeister

Bündeln. Veredeln. Verpacken.

2020



**KWIK LINE FOR LEEKS
LENGTH 9 METERS
WITH 2 STRINGS AND 1 LABEL**

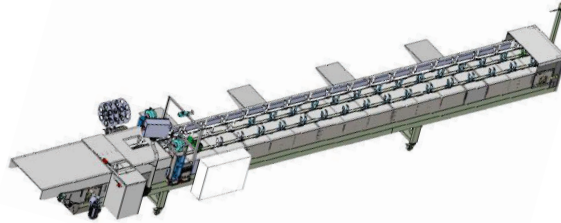

TECHNICAL OFFER

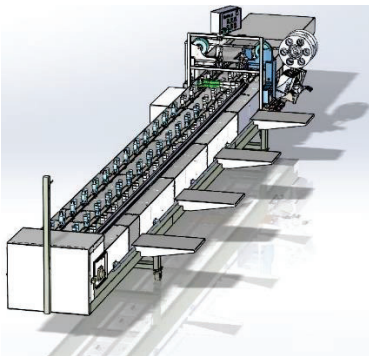

- . Length of the machine 9.51 m
- . Stainless steel frame on wheels
- . 2 stainless steel ARC binders
- . Space between the string 23 cm (can be modified)
- . cutting unit single disc after bunching
- . 3 FDA belts width 50 mm
- . 1 guide on roots side to bunch at the same position
- . 1 spraying ramp with nozzles under the frame to clean the belts
- . Custom made buckets according the shape and size of the product
- . Buckets with pitch of 380 mm - 3000 buckets / hour
- . Adjustable speed of the machine
- . 230 volts single phased
- . Control panel



- . Kwik Lok label displayer 903
- . Stainless steel construction
- . located after the binder on a sliding trolley
- . Sliding stainless steel guide to bring the knot into the closure of the label
- . storage of 4000 labels on the machine
- . CE declaration and user manual supplied



baumeister
Bündeln. Veredeln. Verpacken.

OPTIONS AVAILABLE

PRINTER



- . Fixed printer for lot number, dates etc
- . Motorized printer to print barre codes, logo and various other information.

. Printing on the top of labels

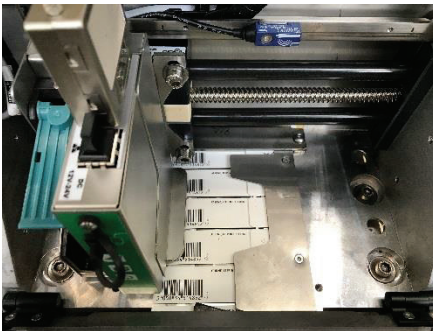

. Cartridge combine with the head of the printer allows no maintenance of the printing head

. Delivered with software Design Line

. 9 labels in memory

. Fast creation of the artwork with Design line





baumeister

Bündeln. Veredeln. Verpacken.

WORKING TABLES



. Set of tables working tables to place crates dimensions 622 mm x 405 mm

. Tables located along the line according requirements

